

WATER BOTTLE MOUNT FOR QUICK-RELEASE AEROBARS

Thanks for buying Redshift Sports Aerobar Water Bottle Mount! Please read these instructions and warnings completely before installing the water bottle mount. If you are unfamiliar with bike maintenance, or if you lack the required tools, please visit your local bike shop or contact Redshift Sports customer service for assistance. Improper installation or use may void the product's warranty policy.

Check out www.redshiftsports.com for instructional videos and other resources.

WATER BOTTLE MOUNT INSTALLATION

1. The water bottle mount may be installed on either the right-hand or left-hand aerobar. Installing it on the right-hand aerobar will place the water bottle further forward, while installing it on the left-hand aerobar will position the water bottle further rearward.
2. Place the mount plate (#1) on top of the aerobar stack with the countersunk conical hole facing upward. If the aerobar armpad is in either of the two narrowest positions, it may be necessary to first remove the armrest plate. See the installation manual for the quick-release aerobars for instructions on removing and reinstalling the armrest plate.
3. Apply a small amount of bicycle grease to the tip of the M5 x 8mm flat head socket cap screw (#2) supplied with the water bottle mount.
4. Insert the M5 x 8mm screw through the conical hole in the mounting plate (#1) and into the threaded hole in the top of the aerobar stack between the two M6 stack bolts.
5. Using a torque wrench (3mm hex), tighten the screw to 3 N-m (27 in-lb).
6. The water bottle cage (#3) may be installed in one of three fore-aft locations on the mount plate (#1).
7. Apply a small amount of bicycle grease to the tips of the M5 x 6mm button head screws (#4).
8. Place the cage in the desired position, insert the button head screws and thread them into the corresponding holes in the mount plate.
9. Using a torque wrench (3mm hex), tighten the screws to 3 N-m (27 in-lb).
10. If you removed the armrest plate in step 2, reattach the armrest plate, and tighten the armrest fasteners to 3 N-m (27 in-lb) using a torque wrench (3mm hex).

** The two larger threaded holes at the outside corners of the mount plate (#1) are for attaching the optional computer mount accessory. For directions on attaching the computer mount, see the computer mount instructions.

⚠ WARNING

- Failure to follow these instructions and warnings may result in malfunction or breakage of this component, possibly causing serious injury or death.
- Always use a torque wrench when installing or adjusting fasteners, and always tighten to Redshift torque specifications (or the bike manufacturer's specification). Periodically check all fasteners for tightness using a torque wrench, since fasteners can loosen under the influence of road vibration.
- Periodically clean and inspect all surfaces of this component for hairline cracks or signs of damage. If you find any cracks or damage, immediately cease using the part and contact Redshift Sports customer service.

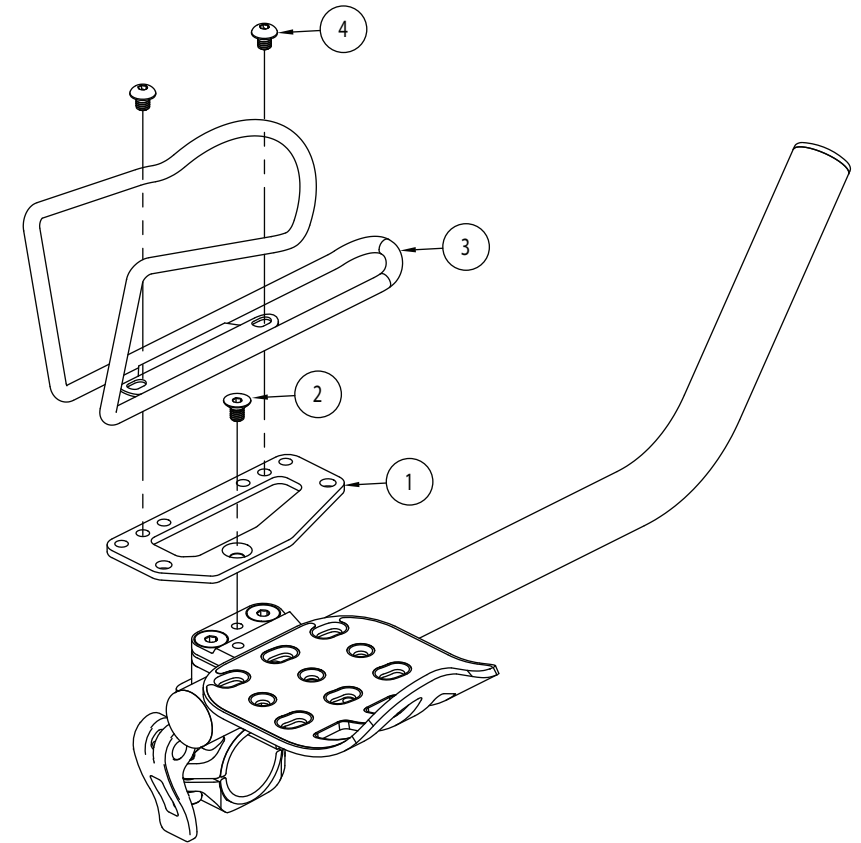

WARRANTY

Redshift Sports LLC warrants that this product is free from defects in material and workmanship for one year from the date of original retail purchase. This warranty applies to the original retail purchaser only, and is not transferable to any subsequent purchaser(s). At their discretion, Redshift Sports will repair or replace the defective product with the same model (or an equivalent model if an identical model is unavailable). This warranty does not cover components that are damaged due to improper installation, improper adjustment, poor maintenance, crashes, abuse, modification, misuse, or other conditions deemed abnormal or excessive by Redshift Sports LLC.

All warranty returns must be accompanied by a Return Authorization Number (RA#) and dated proof-of-purchase. You can obtain an RA# by submitting a warranty claim at www.redshiftsports.com or by emailing returns@redshiftsports.com.