

COMPUTER MOUNT FOR QUICK-RELEASE AEROBARS

Thanks for buying Redshift Sports Aerobar Computer Mount! Please read these instructions and warnings completely before installing the computer mount. If you are unfamiliar with bike maintenance, or if you lack the required tools, please visit your local bike shop or contact Redshift Sports customer service for assistance. Improper installation or use may void the product's warranty policy.

Check out www.redshiftsports.com for instructional videos and other resources.

STANDARD HANDLEBAR INSTALLATION

1. The standard handlebar installation positions your bike computer directly in front of your bicycle's stem for easy viewing while riding in either the road or aero positions.
2. Choose the preferred side for installation of the computer mount. The computer will be positioned centrally, so the specific side is not important.
3. Remove the M6 x 12mm socket head cap screw from the front of the handlebar clamp.
4. Apply a small amount of bicycle grease to the tip of the M6 x 18mm socket head cap screw (#2) supplied with the computer mount.
5. For installation on the right-hand handlebar clamp, position the computer mount (#1) as shown in the figure below. For installation on the left-hand handlebar clamp, simply reverse the orientation of the computer mount so that the round tube points to the right (toward the center of the bicycle).
6. From the bottom, insert the M6 x 18mm screw (#2) through the hole at the end of the computer mount (furthest from the round tube), through the lower handlebar clamp, and thread it into the upper handlebar clamp.

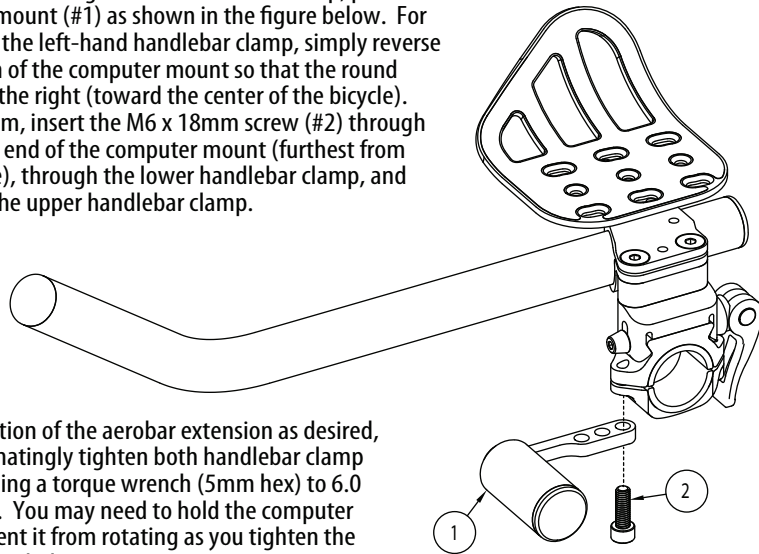

7. Adjust the position of the aerobar extension as desired, and then alternately tighten both handlebar clamp bolts evenly using a torque wrench (5mm hex) to 6.0 N-m (53 in-lb). You may need to hold the computer mount to prevent it from rotating as you tighten the handlebar clamp bolts.
8. Securely clamp your bike computer or accessory to the computer mount tube.

⚠ WARNING

- Failure to follow these instructions and warnings may result in malfunction or breakage of this component, possibly causing serious injury or death.
- Always use a torque wrench when installing or adjusting fasteners, and always tighten to Redshift torque specifications (or the bike manufacturer's specification). Periodically check all fasteners for tightness using a torque wrench, since fasteners can loosen under the influence of road vibration.
- Periodically clean and inspect all surfaces of this component for hairline cracks or signs of damage. If you find any cracks or damage, immediately cease using the part and contact Redshift Sports customer service.
- Ensure that your accessories are securely clamped to the computer mount. Improperly tightened accessories may fall off of the computer mount while riding, possibly causing equipment damage or serious injury or death.

INSTALLATION ON OPTIONAL WATER BOTTLE MOUNT

1. The computer mount may be attached to the rear of the optional water bottle mount to keep your bike computer visible while using the water bottle mount.
2. Attach your bicycle computer securely to the round mounting tube of the computer mount (#1).
3. Apply a small amount of bicycle grease to the tip of the M6 x 10mm button-head cap screw (#3) supplied with the computer mount.
4. Insert the M6 x 10mm button-head cap screw (#3) through one of the three holes in the computer mount. Selecting different holes will adjust the fore-aft position of the computer relative to the water bottle cage. It may be necessary to remove the water bottle cage from the water bottle mount plate in order to insert the computer mount.
5. Thread the screw into the threaded hole toward the rear of the water bottle mount plate next to the water bottle cage.
6. Tighten the screw (#3) using a torque wrench (4mm hex) to 3.0 N-m (27 in-lb). You may need to hold the computer mount to prevent it from rotating as you tighten the screw.

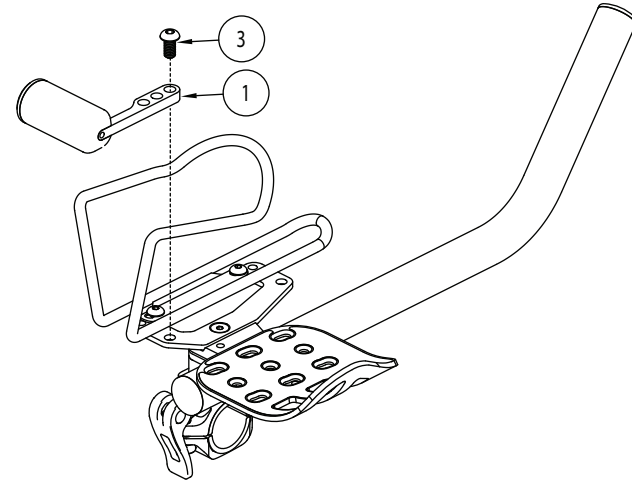

WARRANTY

Redshift Sports LLC warrants that this product is free from defects in material and workmanship for one year from the date of original retail purchase. This warranty applies to the original retail purchaser only, and is not transferable to any subsequent purchaser(s). At their discretion, Redshift Sports will repair or replace the defective product with the same model (or an equivalent model if an identical model is unavailable). This warranty does not cover components that are damaged due to improper installation, improper adjustment, poor maintenance, crashes, abuse, modification, misuse, or other conditions deemed abnormal or excessive by Redshift Sports LLC.

All warranty returns must be accompanied by a Return Authorization Number (RA#) and dated proof-of-purchase. You can obtain an RA# by submitting a warranty claim at www.redshiftsports.com or by emailing returns@redshiftsports.com.